

**SINGER**  
**300W104, W194, W195, W204, W294**

ts  
List

**300W**

From the library of Diamond Needle Corp

VARIETIES — 300W104  
300W194  
300W195  
300W204  
300W294

# SINGER\*

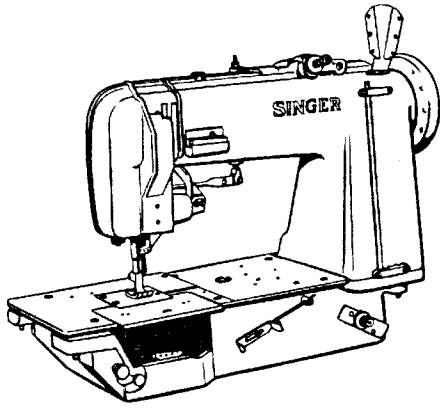

## 300W104 PARTS

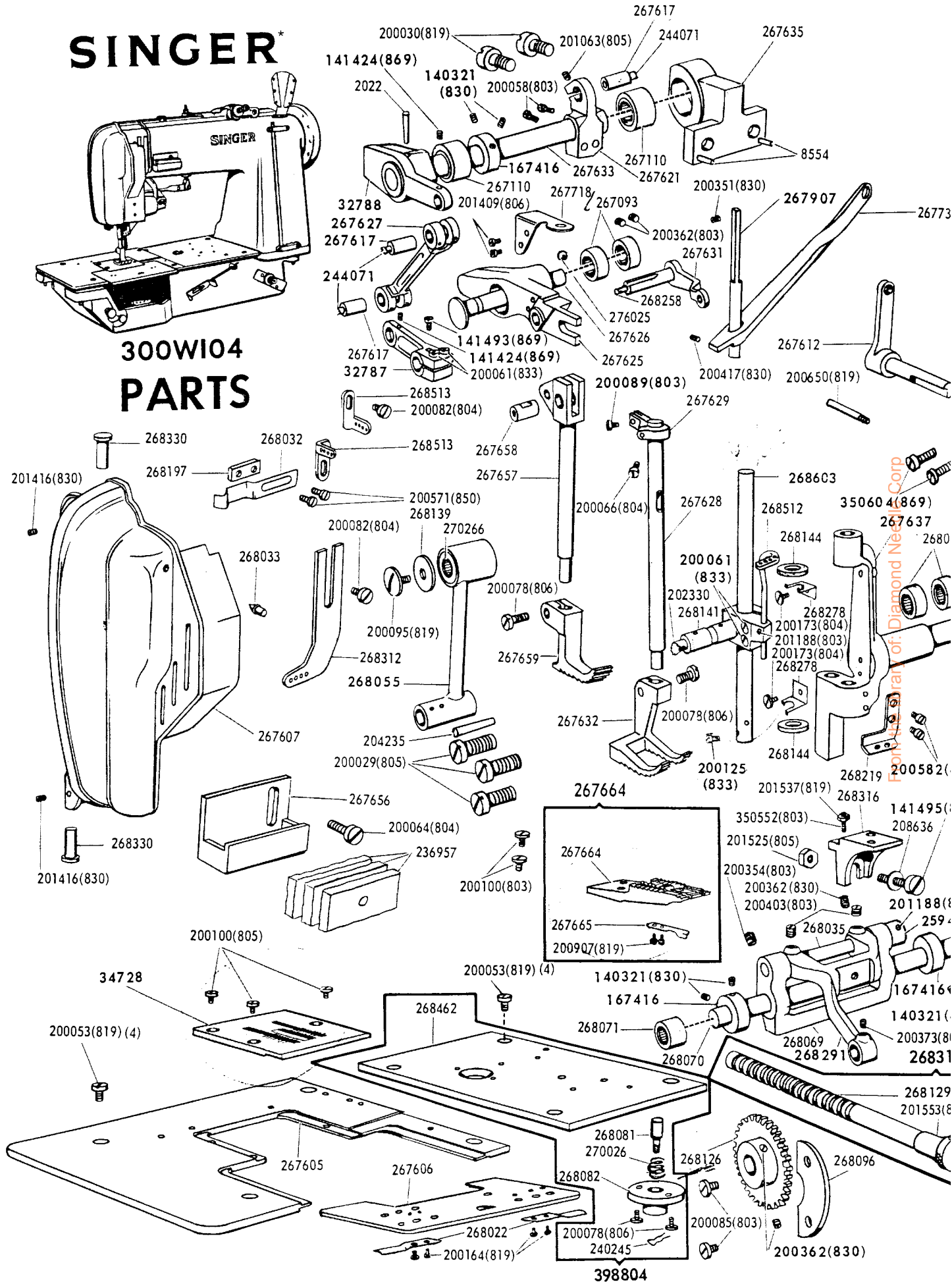





NUMERICAL LIST OF PARTS 300W104 MACHINE

PART NO.	DESCRIPTION	PART NO.	DESCRIPTION
1517(803)	Presser Bar Pressure Cylinder Plunger Nut (2)	141494(869)	Needle Guard Set Screw (Front)
2022	Lifting Rock Shaft Crank Pin	141495(830)	Feed Dog Shank Screw
2102	Needle Thread Tension Disc (2)	167188	Face Plate Lock Spring Plate
8554	Lifting Rock Shaft Bracket Position Pin (2)	167416	Feed Driving Rock Shaft Collar with two 140321(830)(2)
8582	Arm Position Pin (2)	167416	Feed Lifting Rock Shaft Collar with two 140321(830) (2)
10148	Looper Thread Tension Spring	167416	Lifting Rock Shaft Collar with two 140321(830)
22748	Presser Bar Spring Arm Hinge Screw Washer	167416	Spreader Driving Rock Shaft Collar with two 140321(830)(2)
32572	Needle Thread Tension Releasing Disc	200004(805)	Arm Screw (4)
32787	Lifting Crank with 141424(869), 141493(869) and two 200061(833)	200029(805)	Arm Head Screw (3)
32788	Lifting Rock Shaft Crank with 141424(869)	200030(819)	Lifting Rock Shaft Bracket Screw (2)
* 32789	Lifting Rock Shaft 267633 with 2022 and 32788	200035(805)	Spreader Bar Bearing Screw (2)
32825	Spreader Driving Rock Shaft Screw Stud Oil Packing (wick)	200043(803)	Needle Bar Rock Frame Driving Arm Pinch Screw (2)
32835	Feed Driving Eccentric Complete, Nos. 268064, 268065, 268066, 268067 and 268315	200047(804)	Arm Shaft Ball Bearing (back) Housing Screw (3)
32838	Lifting Eccentric and Needle Bar Rock Frame Driving Eccentric complete, Nos. 267610, 267618, 267622, 267639, 268064 and two 268065	200047(805)	Needle Thread Tension Bracket Screw (2)
32848	Arm Shaft Ball Bearing (Front)	200049(804)	Foot Lifter Lever (back) Spring Screw
34728	Throat Plate	200053(819)	Bed Plate Screw (8)
50169(809)	Looper Thread Guide (top of Arm) Bracket Screw (2)	200054(803)	Looper Thread Tube Clamp Screw (4)
50326(803)	Needle Thread Tension Stud	200058(803)	Foot Lifter Arm Pinch Screw
51570(803)	Needle Thread Tension Thumb Nut	200058(803)	Lifting Eccentric Connection Crank Pinch Screw (2)
54279	Needle Thread Tension Thread Guide (double)	200059(805)	Looper Thread Guide Screw
59537	Needle Thread Tension Spring Bushing (front)	200061(833)	Feed Driving Rock Shaft Crank Pinch Screw (2)
59538	Needle Thread Tension Spring Bushing (back)	200061(833)	Feed Lifting Rock Shaft Crank Pinch Screw (2)
59539	Needle Thread Tension Stud 50326(803) with 51570(803)	200061(833)	Lifting Crank Pinch Screw
67425	Looper Carrier Crank Clamping Stud Washer	200061(833)	Needle Bar Connecting Stud Pinch Screw (2)
67425	Presser Bar Pressure Cylinder Support Stud Nut Lock Washer	200064(806)	Looper Thread Take-up Rod Set Screw
131741	Needle Thread Tension Spring	200064(804)	Thread Lubricator Screw
140306(869)	Feed Lifting Crank Pinch Screw	200066(804)	Lifting Presser Bar Guide Block Pinch Screw
140321(830)	Feed Driving Rock Shaft Collar Set Screw (4)	200078(805)	Arm Side Cover Screw (3)
140321(830)	Feed Lifting Rock Shaft Collar Set Screw (4)	200078(806)	Feed Regulating Stud Socket Screw (2)
140321(830)	Lifting Rock Shaft Collar Set Screw (2)	200078(806)	Lifting Presser Foot Pinch Screw
140321(830)	Spreader Driving Rock Shaft Collar Set Screw (4)	200078(806)	Vibrating Presser Foot Pinch Screw
141424(869)	Lifting Link Hinge Pin Set Screw (2)	200082(804)	Needle Thread Guide Screw (2)
141432(819)	Looper Thread Tension Stud	200085(803)	Looper Carrier Shaft Bushing (left) Position Plate Screw (2)
141478(869)	Needle Guard Set Screw (back)	200089(803)	Looper Carrier Crank Hinge Pin Pinch Screw
141493(869)	Lifting Crank Set Screw	200089(803)	Lifting Presser Bar Guide Block Adjusting Screw
		200095(819)	Needle Bar Connecting Link Cap Washer
		200098(806)	Looper Throw-out Safety Latch Spring Bracket Screw (2)
		200098(806)	Presser Bar Pressure Cylinder Support Retainer Screw (2)
		200100(803)	Feed Dog Screw (2)

\* Not illustrated as a complete number

Belt Guard 415433

**NUMERICAL LIST OF PARTS 300W104 MACHINE**

<b>PART NO.</b>	<b>DESCRIPTION</b>	<b>PART NO.</b>	<b>DESCRIPTION</b>
201572(819)	Looper Thread Tension Thumb Nut	267093	Lifting Lever Needle Bearing (2)
201620(804)	Looper Throw-out Gear	267110	Lifting Rock Shaft Needle Bearing (2)
201622(819)	Locking Plunger Thumb Nut	267603	Arm Shaft with 268009, 268044, 268264, two each 268214 and 350534(803)
201622(819)	Presser Bar Spring Arm Hinge Screw Nut	267605	Bed Plate (left)
201736(805)	Spreader Driving Rock Shaft Screw Stud Nut	267606	Bed Plate Slide with two 268022 and four 200164(819)
201746(819)	Presser Bar Pressure Cylinder Support Stud Nut(3)	267607	Face Plate with 268003 and two 201416(830)
202005	Arm Screw Washer (4)	267610	Lifting Eccentric
202253	Arm Shaft Connection Belt Pulley Spring Flange (2)	267612	Foot Lifter Crank
202330	Needle Bar Connecting Stud Oil Packing (wick)	267617	Lifting Eccentric Connection Hinge Pin with 244071
204235	Arm Head Position Pin	267617	Lifting Link Hinge Pin with 244071 (2)
204348	Foot Lifter Lever Spring	267618	Lifting Eccentric Adjusting Disc Spring
204365	Needle Thread Tension Releaser Spring	267621	Lifting Eccentric Connection Crank with 201063(805) and two 200058(803)
204925	Looper Driving Crank Oil Hole Cover Screw Washer	267622	Lifting Eccentric Flange with 267623, two each 241763, 350467(803), 350477(830) and 350548(803)
204925	Spreader Screw Washer	267623	Feed Driving Eccentric Friction Plate
206133	Foot Lifter Lever Rod Hinge Screw Washer	267623	Needle Bar Rock Frame Driving Eccentric Friction Plate
208636	Feed Dog Shank Screw Washer	267623	Lifting Eccentric Friction Plate
208636	Looper Holder Screw Washer	267624	Lifting Eccentric Spacing Collar with two 200380(830)
214529	Needle Bar Rock Frame Regulating Stud Spring	267625	Lifting Lever with two 267093
226206	Needle Thread Tension Releasing Pin	267625	Lifting Lever Hinge Stud
228448	Machine Locating Stud (4)	267627	Lifting Link
236957	Thread Lubricator Oil Pad (felt) (3)	267628	Lifting Presser Bar
238089	Needle Thread Tension Releasing Plate Pin	267629	Lifting Presser Bar Guide Block with 200066(804) and 200089(803)
240245	Feed Regulating Stud Retaining Spring	267631	Lifting Presser Bar Lifting Crank with 268258
241763	Feed Driving Eccentric Friction Plate Screw Set Screw Packing (brass) (2)	267632	Lifting Presser Foot with 200078(806)
241763	Lifting Eccentric Friction Plate Screw Set Screw Packing (brass) (2)	267633	Lifting Rock Shaft
241763	Needle Bar Rock Frame Driving Eccentric Friction Plate Screw Set Screw Packing (brass) (2)	267635	Lifting Rock Shaft Bracket
244048	Looper Thread Tension Disc (2)	267637	Needle Bar Rock Frame
244071	Lifting Eccentric Connection Hinge Pin Oil Packing (wick)	267638	Needle Bar Rock Frame Driving Arm with two 200043(803)
244071	Lifting Link Hinge Pin Oil Packing (wick)	267639	Needle Bar Rock Frame Driving Eccentric Flange with 267623, two each 241763, 350467(830), 350477(830) and 350548(830)
248423	Foot Lifter Rod Cotter Pin	267644	Presser Bar Spring Arm Fork
250265	Looper Throw-out Gear Locking Plunger Spring	267645	Presser Bar Spring Arm Fork Lock Washer (nylon)
259470	Feed Bar Hinge Pin Collar with 201188(803)		
264709	Needle Bar Rock Frame Regulating Stud Cap with 200364(830)		

**NUMERICAL LIST OF PARTS 300W104 MACHINE**

<b>PART NO.</b>	<b>DESCRIPTION</b>	<b>PART NO.</b>	<b>DESCRIPTION</b>
200100(805)	Throat Plate Screw	200571(850)	Face Plate Lock Spring Screw (2)
<del>200125(833)</del>	<del>Needle Set Screw</del>	200573(804)	Looper Driving Crank Oil Stop Screw
200164(819)	Bed Plate Slide Spring Screw (4)	200578(850)	Looper Thread Guide (top of arm) Bracket Screw (2)
200173(804)	Needle Bar Oiling Felt Holder Screw (2)	200582(803)	Needle Bar Rock Frame Thread Guide Screw (2)
200303(819)	Looper Driving Crank Oil Hole Cover Screw	200650(819)	Foot Lifter Crank Stop Screw Stud
200327(803)	Machine Pulley Set Screw	200907(819)	Loop Deflector Screw (2)
200328(830)	Machine Pulley Position Screw	200928(850)	Presser Bar Spring Arm Hinge Screw
200337(803)	Needle Bar Rock Frame Regulating Stud Sleeve Set Screw	201020(805)	Spreader Driving Connection Cap Screw (2)
200344(830)	Looper Driving Crank Position Screw (2)	201052(833)	Needle Thread Tension Releaser Cap Set Screw
200346(803)	Needle Bar Crank Set Screw	201063(805)	Lifting Eccentric Connection Hinge Pin Pinch Screw
200351(830)	Lifting Presser Bar Guide Rod Set Screw (upper)	201110(819)	Presser Bar Pressure Cylinder Cap Screw (2)
200354(803)	Feed Driving Rock Frame Position Screw	201160(805)	Foot Lifter Lever Spring Screw Eye
200354(803)	Looper Carrier Shaft Bushing Position Screw (2)	201185(804)	Feed Driving Connection Cap Screw
200354(803)	Needle Bar Crank Position Screw	201185(804)	Needle Bar Rock Frame Driving Connection Cap Screw
200362(830)	Feed Driving Rock Frame Set Screw	201188(803)	Needle Thread Guide (on Needle Bar Connecting Stud) Set Screw
200362(803)	Lifting Lever Hinge Stud Set Screw (2)	201188(803)	Feed Bar Hinge Pin Collar Set Screw
200362(830)	Looper Carrier Shaft Bushing Set Screw (2)	201254(830)	Arm Shaft Connection Belt Pulley Set Screw (2)
200362(830)	Looper Driving Crank Set Screw	201254(830)	Bed Shaft Connection Belt Pulley Set Screw (2)
200362(830)	Looper Throw-out Gear Set Screw (2)	201363(803)	Foot Lifter Lever Hinge Screw
200364(830)	Spreader Driving Eccentric Counterbalance Set Screw (2)	201409(806)	Presser Bar Spring Arm Ball Bearing Retainer Screw (2)
200364(803)	Spreader Driving Eccentric Set Screw (2)	201416(830)	Face Plate Hinge Stud Set Screw (2)
200364(830)	Looper Throw-out Gear Locking Plunger Stop Screw Set Screw	201418(803)	Feed Lifting Rock Shaft Crank Position Screw
200364(830)	Needle Bar Rock Frame Regulating Stud Cap Set Screw	201477(803)	Looper Throw-out Gear Locking Plunger Screw Bushing
200373(803)	Feed Lifting Link Hinge Pin Set Screw (2)	201522(805)	Feed Driving Connection Hinge Stud Nut
200373(803)	Foot Lifter Arm Set Screw	201522(805)	Feed Lifting Connection Hinge Stud Nut
200373(803)	Spreader Driving Crank Position Screw	201522(805)	Needle Bar Rock Frame Driving Connection Hinge Stud Nut
200378(803)	Needle Bar Crank Position Screw Check Screw	201524(805)	Looper Carrier Crank Clamping Stud Nut
200380(830)	Lifter Eccentric Spacing Collar Set Screw (2)	201525(805)	Feed Dog Shank Screw Lock Nut
200380(830)	Spreader Holder Set Screw (2)	201526(805)	Foot Lifter Lever Rod Hinge Screw Nut
200382(833)	Feed Driving Eccentric Adjusting Disc Spring Collar Set Screw (2)	201537(819)	Feed Dog Shank Adjusting Screw Lock Nut
200394(803)	Feed Lifting Eccentric Set Screw (2)	201553(804)	Looper Throw-out Rack Rod Thumb Nut
200403(830)	Feed Bar Set Screw (2)		
200403(830)	Spreader Driving Crank Set Screw		
200417(830)	Lifting Presser Bar Guide Rod Set Screw (lower)		
200444(803)	Looper Throw-out Gear Locking Plunger Stop Screw		
200562(805)	Looper Thread Tension Bracket Screw (2)		



NUMERICAL LIST OF PARTS 300W104 MACHINE

PART NO.	DESCRIPTION	PART NO.	DESCRIPTION
268063	Feed Driving Connection Needle Bearing	268123	Looper Thread Tube
268063	Needle Bar Rock Frame Driving Connection Needle Bearing	268124	Looper Thread Tube Clamp (2)
268063	Spreader Driving Connection Needle Bearing	268126	Looper Throw-out Gear with two 200362(830)
268064	Feed Driving Eccentric	268127	Looper Throw-out Gear Locking Plunger
268064	Needle Bar Rock Frame Driving Eccentric	268129	Looper Throw-out Rack Rod
268065	Feed Driving Eccentric Adjusting Disc	268131	Looper Throw-out Safety Latch
268065	Lifting Eccentric Adjusting Disc	268132	Looper Throw-out Safety Latch Spring
268065	Needle Bar Rock Frame Driving Eccentric Adjusting Disc	268133	Looper Throw-out Safety Latch Spring Bracket
268066	Feed Driving Eccentric Adjusting Disc Spring	268139	Needle Bar Connecting Link Cap Washer
268067	Feed Driving Eccentric Adjusting Disc Spring Collar with two 200382(833)	268141	Needle Bar Connecting Stud with 201188(803), 202330 and two 200061(833)
268069	Feed Driving Rock Frame with 200354(803) and 200362(803)	268144	Needle Bar Oiling Felt (2)
268070	Feed Driving Rock Shaft	268148	Needle Bar Rock Frame Regulating Stud
268071	Feed Driving Rock Shaft Needle Bearing (2)	268149	Needle Bar Rock Frame Regulating Stud Sleeve
268071	Feed Lifting Rock Shaft Needle Bearing (2)	268150	Needle Bar Rock Frame Regulating Stud complete, Nos. 214529, 264709, 268148 and 268149
268071	Spreader Driving Rock Shaft Needle Bearing (2)	268162	Spreader Point
268073	Feed Driving Rock Shaft Crank with two 200061(833)	268167	Needle Thread Tension Bracket
268074	Feed Lifting Connection	268168	Needle Thread Tension Releaser
268075	Feed Lifting Crank with 140306(869) and 200373(803)	268169	Needle Thread Tension Releaser Cap with 201052(833)
268077	Feed Lifting Eccentric Lubricating Pad (wood)	268181	Spreader Bar
268078	Feed Lifting Link	268184	Spreader Bar Bearing
268079	Feed Lifting Link Hinge Pin with 268258 (2)	268185	Spreader Holder with two 200380(830)
268081	Feed Regulating Stud	268186	Spreader Driving Connection with two 201020(805)
268082	Feed Regulating Stud Socket	268187	Spreader Driving Crank with 200373(803) and 200403(830)
268085	Foot Lifter Lever with 238089	268190	Spreader Driving Pin
268094	Looper Carrier Shaft 268093 with 268095 and 268097	268198	Feed Lifting Rock Shaft Crank with 201418(803) and two 200061(833)
268096	Looper Carrier Shaft Bushing (left) Position Plate	268208	Looper Carrier Crank Hinge Pin with 268258
268098	Looper Driving Connection	268214	Arm Shaft Oil Stop Ball 5/32 in. diam. (2)
268099	Looper Driving Connection Needle Bearing	268214	Bed Shaft Oil Stop Ball
268099	Looper Carrier Needle Bearing (2)	268216	Looper Driving Connection 268098 with 268099
268102	Looper Driving Crank Oil Hole Cover	268219	Needle Bar Rock Frame Thread Guide
268111	Looper Thread Guide (top of Arm) Bracket	268220	Spreader Driving Eccentric Thrust Washer (2)
268121	Looper Thread Tension Bracket Spacking Collar (2)	268233	Spreader Driving Connection 268186 with 268063 and 351876
268121	Needle Thread Tension Bracket Spacing Collar (2)		

**NUMERICAL LIST OF PARTS 300W104 MACHINE**

PART NO.	DESCRIPTION	PART NO.	DESCRIPTION
267645	Presser Bar Pressure Cylinder Hose Connection Washer	268004	Arm Shaft Ball Bearing (back) Housing
267650	Presser Bar Pressure Cylinder Support Retainer	268006	Arm Shaft Connection Belt Pulley with two each 201254(830) and 202253
267653	Presser Bar Pressure Cylinder Plunger Bushing	268009	Arm Shaft Oil Stop Ball Spring (front)
267656	Thread Lubricator with three 236957	268022	Bed Plate Slide Spring (2)
267657	Vibrating Presser Bar	268024	Arm Shaft Ball Bearing (back)
267658	Vibrating Presser Bar Hinge Stud	268024	Bed Shaft Ball Bearing
267659	Vibrating Presser Foot with 200078(806)	268028	Bed Shaft Connection Belt Pulley with two 201254(830)
267664	Feed Dog, 40 needle hole, with 267665, and two 200907(819), for 267663	268029	Bed Shaft Needle Bearing (2)
267665	Loop Deflector	268029	Needle Bar Rock Frame Needle Bearing (2)
267701	Arm Side Cover	268032	Face Plate Lock Spring
267702	Foot Lifter Arm with 200058(803) and 200373(803)	268033	Face Plate Lock Stud
267704	Foot Lifter Lever Rod with 248423	268035	Feed Bar Hinge Pin
267705	Needle Bar Crank with 200346(803), 200354(803) and 200378(803)	268044	Arm Shaft Oil Stop Ball Spring (rear)
267706	Needle Bar Crank 267705 with 32848	268044	Bed Shaft Oil Stop Ball Spring
267707	Needle Thread Tension Releasing Plate (adjustable)	268045	Spreader Driving Eccentric with two 200364(803)
267708	Presser Bar Pressure Cylinder with 267653	268046	Spreader Driving Eccentric Counterbalance with two 200364(830)
267709	Presser Bar Pressure Cylinder Cap	268047	Feed Lifting Eccentric with 268077 and two 200394(803)
267710	Presser Bar Pressure Cylinder Plunger	268048	Machine Pulley (aluminum alloy casting) for "V" belt (outside diameter of belt groove 2.9 inches) with 200327(803) and 200328(803)
267711	Presser Bar Pressure Cylinder Plunger Disc	<del>268049</del>	<del>Machine Pulley 268048</del> with 268024
267712	Presser Bar Pressure Cylinder Plunger Washer (leather)	268051	Looper Thread Guide
267713	Presser Bar Pressure Cylinder Plunger Washer (steel)	268052	Looper Thread Take-up Rod
267714	Presser Bar Pressure Cylinder Support	268053	Spreader Driving Rock Shaft with 200064(806)
267715	Presser Bar Pressure Cylinder complete, Nos. 67425, 267644, 267708, 267709, 267710, 267711, 267712, 267713, 267716, 350579(819), 994778, two each 1517(803), 201110(819) 267645 and three 201746(819)	268054	Bed Shaft with 268044, 268214, 268265 and 350534(803)
267716	Presser Bar Spring	268055	Needle Bar Connecting Link with two 270266
267718	Presser Bar Spring Arm Ball Bearing Retainer	268060	Feed Driving Connection
267719	Presser Bar Spring Arm Fulcrum	268060	Needle Bar Rock Frame Driving Connection
267738	Presser Bar Spring Arm	268061	Feed Driving Connection 268060 with 268063
267907	Lifting Presser Bar Guide Rod	268061	Needle Bar Rock Frame Driving Connection 268060 with 268063
267933	Feed Lifting Rock Shaft	268062	Feed Driving Connection Hinge Stud with 268258
		268062	Feed Lifting Connection Hinge Stud with 268258
		268062	Needle Bar Rock Frame Driving Connection Hinge Stud with 268258

NUMERICAL LIST OF PARTS 300W104 MACHINE

PART NO.	DESCRIPTION	PART NO.	DESCRIPTION	
350534(803)	Bed Shaft Oil Stop Ball Screw		<b>ACCESSORIES</b>	
350548(803)	Feed Driving Eccentric Friction Plate Screw (2)	994719		Air Compressor for Electric Transmitters Nos. 547 and 569
350548(803)	Lifting Eccentric Friction Plate Screw (2)	995475		Air Filter
350548(803)	Needle Bar Rock Frame Driving Eccentric Friction Plate Screw (2)	160137		Air Hose
350552(830)	Feed Dog Shank Adjusting Screw	265307		Bed Hinge Connection (2)
350579(819)	Presser Bar Pressure Cylinder Support Stud	350598		Bed Hinge Connection Screw (4)
350604(869)	Presser Bar Spring Arm Fulcrum Set Screw (2)	228731		Drip Pan
351876	Spreader Driving Rock Shaft Screw Stud Ball Roller	200019		Drip Pan Screw (4)
* 398803	Looper Carrier 268368 with 67425, 201524(805), 268208, 268216, 268307 and 268308	232365		Foot Lifter Treadle Chain 41-1/2 in. long with two 202784
398804	Bed Plate (right) 268462 with 240245, 268081, 268082, 270026 and two 200078(806)	268340		Looper Threading Wire
398812	Feed Driving Rock Shaft Crank 268073 with 201185(804), 201522(805), 268061 and 268062	167447		Machine Base Oil Drain Jar
* 398817	Looper Driving Crank 268277 with 200303(819), 201522(805), 204925, 268047, 268062, 268074, 268102 and 268198	228444		Machine Cushion (neoprene) (4)
398828	Needle Bar Rock Frame Driving Arm 267638 with 200185(804), 201522(805), 268061 and 268062	228733		Machine Rest (left)
* 398854	Needle Bar Crank 267706 with 200095(819), 267603, 268055, 268139 and 268141	228734		Machine Rest (right)
* 398855	Lifting Lever 267625 with 267631, 267718, 276025 and two 201409(806)	41400		Machine Rest Pin
* 398857	Foot Lifter Lever 268085 with 201160(805), 201526(805), 206133, 267704, 267707 and 350524(819)	Cat. No. 4112		Needles (62x59) Size 23 (6)
* 398865	Lifting Rock Shaft 32789 with 32787, 167416, 267621, 267627, 268491 and three 267617	267722		Presser Bar Pressure Control Valve complete
* 398872	Needle Bar Rock Frame 267637 with 267657, 268603 and two each 200173(804), 268144 and 268278	228491		Pressure Oiler
994778	Presser Bar Pressure Cylinder Hose Connection	228745		Thread Unwinder complete
		120341		Tweezers
		21887	Wrench	
		202784	Foot Lifter Treadle Chain Hook (2)	
* Not illustrated as a complete number				

From the library of: Diamond Needle Corp

NUMERICAL LIST OF PARTS 300W104 MACHINE

PART NO.	DESCRIPTION	PART NO.	DESCRIPTION
268258	Feed Driving Connection Hinge Stud Oil Packing (wick)	268368	Looper Carrier 268367 with two 268099
268258	Feed Lifting Connection Hinge Stud Oil Packing (wick)	268373	Looper Thread Guide (on bed at looper) for all gauges from 3/16 to 2 inches
268258	Feed Lifting Link Hinge Pin Oil Packing (wick) (2)	268380	Looper with 141478(869) and 141494(860)
268258	Lifting Presser Bar Lifting Crank Oil Packing (wick)	268382	Looper and Needle Guard complete, Nos. 268310 and 268380
268258	Looper Carrier Crank Hinge Pin Oil Packing (wick)	268462	Bed Plate (right)
268258	Needle Bar Rock Frame Driving Connection Hinge Stud Oil Packing (wick)	268490	Lifting Eccentric Connection
268261	Bed Shaft Connection Belt Pulley 268028 with 268024	268491	Lifting Eccentric Connection 268490 with 271055
268263	Needle Thread Tension complete, Nos. 32572, 59537, 59538, 59539, 131741 and two 2102	268495	Looper Throw-out Safety Latch Retaining Ring
268264	Arm Shaft Oil Control Rod (wood)	268505	Looper Thread Guide (Top of Arm)
268265	Bed Shaft Oil Control Rod (wood)	268506	Looper Thread Guide (top of Arm) Bracket 268111 with 268505 and two 50169(809)
268270	Arm Shaft Connection Belt (reinforced neoprene)	268512	Needle Thread Guide (on Needle Bar Connecting Stud)
268277	Looper Driving Crank with 200362(803), 200573(804) and two 200344(830)	268513	Needle Thread Guide (on side of Arm) (2)
268278	Needle Bar Oiling Felt Holder (2)	268602	Looper Holder with two 350478(833)
268291	Feed Bar with 200373(803) and two 200403(830)	268603	Needle Bar with 200125(833)
268307	Looper Carrier Crank with 200089(803)	268638	Spreader with 268162
268308	Looper Carrier Crank Clamping Stud	270026	Feed Regulating Stud Spring
268310	Needle Guard	270266	Needle Bar Connecting Link Needle Bearing (2)
268312	Needle Thread Guide (on Arm Head)	271055	Lifting Eccentric Connection Needle Bearing
268313	Looper throw-out Gear Locking Plunger Handle	276025	Presser Bar Spring Arm Ball Bearing
268314	Looper Throw-out Rack Rod 268129 with 201553(804)	350149(803)	Spreader Screw
268315	Feed Driving Flange with 267623, two each 241763, 350467(803), 350477(830) and 350548(803)	350267(805)	Looper Holder Screw
268316	Feed Dog Shank with 201537(819) and 350552(830)	350466(803)	Spreader Driving Rock Shaft Screw Stud with 32825
268330	Face Plate Hinge Stud (2)	350467(803)	Feed Driving Flange Set Screw (2)
268331	Looper Thread Tension Bracket	350467(803)	Lifting Eccentric Flange Set Screw (2)
268332	Looper Thread Tension complete, Nos. 10148, 141432(819), 201572(819) and two 244048	350467(803)	Needle Bar Rock Frame Driving Eccentric Flange Set Screw (2)
268333	Looper Thread Tension Thread Guide	350468(805)	Looper Thread Guide (on bed at looper) Screw
268367	Looper Carrier	350477(830)	Feed Driving Eccentric Friction Plate Screw Set Screw (2)
		350477(830)	Lifting Eccentric Friction Plate Screw Set Screw (2)
		350477(830)	Needle Bar Rock Frame Driving Eccentric Friction Plate Screw Set Screw (2)
		350478(833)	Looper Set Screw
		350478(833)	Looper Adjusting Screw
		350524(819)	Foot Lifter Lever Rod Hinge Screw
		350534(803)	Arm Shaft Oil Stop Ball Ball (2)

CHANGE 300W104 LIST AS INDICATED

300W104 NUMBER	NEW NUMBER	DESCRIPTION	300W104 NUMBER	NEW NUMBER	DESCRIPTION
	or 268104	Looper Holder with four 350478(833) for 3/8" to 5/8" gauges. Furnished as regular to machine in standard gauges of 3/8" (Code 024) and 1/2" (Code 032). NOTE: When ordering, state code or gauge required.		or 267853	Throat Plate for 11/32" to 13/32" gauges. Furnished as regular to machine in standard gauges of 3/8" (Code 024). NOTE: When ordering, state code or gauge required.
	or 268105	Looper Holder with four 350478(833) for 21/32" to 7/8" gauges. Furnished as regular to machine in standard gauge of 3/4" (Code 048). NOTE: When ordering state code or gauge required.		or 267855	Throat Plate for 7/16" to 1/2" gauges. Furnished as regular to machine in standard gauge of 1/2" (Code 032). NOTE: When ordering, state code or gauge required.
268503 398872	268136 398867	Needle Bar Needle Bar Rock Frame 267637 with 267657, 268136 and two each 200173(804), 268144 and 268278		or 267858	Throat Plate for 11/16" to 31/32" gauges. Furnished as regular to machine in standard gauge of 3/4" (Code 048). NOTE: When ordering, state code or gauge required.
200125(833) 268638	omit part 268374	Needle Set Screw Spreader with two 268162 for 3/16", 1/4" and 5/16" gauges. Furnished as regular to machine in standard gauges of 1/4" (Code 016) and 5/16" (Code 020). NOTE: When ordering, state code or gauge required.	267659	267679	Vibrating Presser Foot (40 Needle hole) with 200078(806) for 3/16" to 11/32" gauges. Furnished as regular to machine in standard gauges of 1/4" (Code 016) and 5/16" (Code 020). NOTE: When ordering, state code or gauge required.
	or 268375	Spreader with two 268312 for 3/8", 1/2" and 5/8" gauges. Furnished as regular to machine in standard gauges of 3/8" (Code 024) and 1/2" (Code 032). NOTE: When ordering, state code or gauges required.		or 267680	Vibrating Presser Foot (40 Needle hole) with 200078(806) for 3/8" to 1" gauges. Furnished as regular to machine in standard gauges of 3/8" (Code 024), 1/2" (Code 032) and 3/4" (Code 048). NOTE: When ordering, state code or gauge required.
	or 268376	Spreader with two 268312 for 3/4" gauge. Furnished as regular to machine in standard gauge of 3/4" (Code 048).			
228745 34728	228746 267851	Thread Unwinder Complete Throat Plate for 3/16" to 5/16" gauges. Furnished as regular to machine in standard gauges of 1/4" (Code 016) and 5/16" (Code 020). NOTE: When ordering, state code or gauge required.			

**SUPPLEMENTARY PARTS LIST FOR MACHINES 300W194 and 300W294**  
 (Same as Complete List for MACHINE 300W104 with the following EXCEPTIONS)

CHANGE 300W104 LIST AS INDICATED

300W104 NUMBER	NEW NUMBER	DESCRIPTION	300W104 NUMBER	NEW NUMBER	DESCRIPTION
<u>FOR 300W194 AND 300W294</u>					
994719	omit part	Air Compressor		or	
995475	omit part	Air Filter	267804		Feed Dog (46 Needle hole) with two 268138 and four 200172(805) for 11/32", 3/8" and 13/32" gauges. Furnished as regular to machine in standard gauge of 3/8" (Code 024).
160137	omit part	Air Hose			
268462	268403	Bed Plate (right)			
268064	267610	Feed Driving Eccentric			
32835	32840	Feed Driving Eccentric Complete, Nos. 267610, 268065, 268066, 268067 and 268315			NOTE: When ordering, state code or gauge required.
32838	32839	Lifting Eccentric and Needle Bar Rock Frame Driving Eccentric Complete, Nos. 267618, 267622, 267639, two each 267610 and 268065		or	
			267812		Feed Dog (46 Needle hole) with two 268318 and four 200172(805) for 7/16", 15/32" and 1/2" gauges. Furnished as regular to machine in standard gauge of 1/2" (Code 032).
268367	268090	Looper Carrier			NOTE: When ordering, state code or gauge required.
268368	268205	Looper Carrier 268090 with 268099		or	
268064	267610	Needle Bar Rock Frame Driving Eccentric	267821		Feed Dog (46 Needle hole) with two 268318 and four 200172(805) for 11/16" to 31/32" gauges. Furnished as regular to machine in standard gauge of 3/4" (Code 048).
167447	167448	Machine Base Oil Drain Jar			NOTE: When ordering, state code or gauge required.
267722	omit part	Presser Bar Pressure Control Valve Complete			
<u>FOR 300W194 ONLY</u>					
268060	267608	Feed Driving Connection			
268061	267609	Feed Driving Connection 267608 with 271055			
268063	271055	Feed Driving Connection Needle Bearing			
398812	32845	Feed Driving Rock Shaft Crank 268073 with 201185(804), 201522(805), 267609 and 268062			NOTE: When ordering, state code or gauge required.
398828	32846	Needle Bar Rock Frame Driving Arm 267638 with 201185(804), 201522(805), 267609 and 268062	267665	268318	Loop Deflector (2)
			200907(819)	200172(805)	Loop Deflector Screw (4)
			267632	267676	Lifting Presser Foot with 200078(806) for 3/16" to 11/32" gauges. Furnished as regular to machine in standard gauges of 1/4" (Code 016) and 5/16" (Code 020).
268060	267608	Needle Bar Rock Frame Driving Connection			NOTE: When ordering, state code or gauge required.
268061	267609	Needle Bar Rock Frame Driving Connection 267608 with 271055			
Cat. 4112	Cat. 4116	Needle (Size 23)		or	
268063	271055	Needle Bar Rock Frame Driving Connection Needle Bearing	267677		Lifting Presser Foot with 200078(806) for 3/8" to 1" gauges. Furnished as regular to machine in standard gauges of 3/8" (Code 024), 1/2" (Code 032) and 3/4" (Code 048).
34728	32827	Throat Plate			NOTE: When ordering, state code or gauge required.
<u>FOR 300W294 ONLY</u>					
267606	268017	Bed Plate Slide with two 268022 and four 200138(804)			
200164(819)	200138(804)	Bed Plate Slide Spring Screw (4)			
267664	267802	Feed Dog (46 Needle hole) with two 268318 and four 200172(805) for 1/4", 9/32" and 5/16" gauges. Furnished as regular to machine in standard gauges of 1/4" (Code 016) and 5/16" (Code 020).			NOTE: When ordering, state code or gauge required.
		NOTE: When ordering, state code or gauge required.	268602	268103	Looper Holder with four 350478(833) for 3/16" to 11/32" gauges. Furnished as regular to the machine in standard gauges of 1/4" (Code 016) and 5/16" (Code 020).
					NOTE: When ordering, state code or gauge required.

**SUPPLEMENTARY PARTS LIST FOR MACHINE 300W195**  
 (Same as Complete List for MACHINE 300W104 with the following EXCEPTIONS)

CHANGE 300W104 LIST AS INDICATED

300W104 NUMBER	NEW NUMBER	DESCRIPTION	300W104 NUMBER	NEW NUMBER	DESCRIPTION
267603	267923	Arm Shaft with 268009, 268044, 268264 and two each 268214 and 350534(803)	268367	268090	Looper Carrier
267701	omit part	Arm Side Cover	268368	268205	Looper Carrier 268090 with two 268099
200078(805)	omit part	Arm Side Cover Screw (3)	398803	omit part	Looper Carrier 268368 with 67425, 201524(805), 268208, 268216, 268307 and 268308
268462	268403	Bed Plate (right)	Cat. 4112	Cat. 4372	Needle
268060	267608	Feed Driving Connection	268603	267921	Needle Bar with 200125(833)
268061	267609	Feed Driving Connection 267608 with 271055	267705	267912	Needle Bar Crank with 32848, 200346(803), 200354(830), and 200378(803)
268063	271055	Feed Driving Connection Needle Bearing	267706	omit part	Needle Bar Crank 267705 with 32848
268064	267610	Feed Driving Eccentric	398854	398870	Needle Bar Crank 267912 with 200095(819), 267923, 268055, 268139 and 268141
32835	32840	Feed Driving Eccentric complete, Nos. 267610, 268065, 268066, 268067 and 268315	268144	omit part	Needle Bar Oiling Felt
398812	32845	Feed Driving Rock Shaft Crank 268073 with 201185(804), 201522(805), 267609 and 268062	268278	omit part	Needle Bar Oiling Felt Holder
267702	267915	Foot Lifter Arm with 200058(803) and 200373(803)	200173(804)	omit part	Needle Bar Oiling Felt Holder Screw
200650(819)	omit part	Foot Lifter Crank Stop Screw Stud	267637	267917	Needle Bar Rock Frame
204348	267935	Foot Lifter Lever (back) Spring	398872	398871	Needle Bar Rock Frame 267917 with 267918 and 267921
32787	267906	Lifting Crank with 141424(869), 141493(869) and two 200061(833)	398828	267929	Needle Bar Rock Frame Driving Arm 267638 with 201185(804), 201522(805), 267609, 268062 and two 204925
267618	omit part	Lifting Eccentric	268060	267608	Needle Bar Rock Frame Driving Connection
267622	267922	Adjusting Disc Spring	268061	267609	Needle Bar Rock Frame Driving Connection 267608 with 271055
267622	267922	Lifting Eccentric Flange with 267623, two each 241763, 350467(830), 350477(830) and 350548(803)	268063	271055	Needle Bar Rock Frame Driving Connection Needle Bearing
32838	omit part	Lifting Eccentric and Needle Bar Rock Frame	268064	267610	Needle Bar Rock Frame Driving Eccentric
267624	omit part	Driving Eccentric complete, Nos. 267610, 267618, 267622, 267639, 268064 and two 268065	267639	268315	Needle Bar Rock Frame Driving Eccentric Flange with 267623, two each 241763, 350467(830), 350477(830) and 350548(803)
267624	omit part	Lifting Eccentric Spacing Collar with two 200380(830)	268148	omit part	Needle Bar Rock Frame Regulating Stud
200380(830)	omit part	Lifting Eccentric Spacing Collar Set Screw	264709	omit part	Needle Bar Rock Frame Regulating Stud Cap with 200364(830)
398855	398869	Lifting Lever 267625 with 267718, 267908, 267025 and two 201409(806)	200364(830)	omit part	Needle Bar Rock Frame Regulating Stud Cap Set Screw
267628	267920	Lifting Presser Bar	268149	omit part	Needle Bar Rock Frame Regulating Stud Sleeve
267629	omit part	Lifting Presser Bar Guide Block with 200066(804) and 200089(803)	200337(803)	omit part	Needle Bar Rock Frame Regulating Stud Sleeve Set Screw
200089(803)	omit part	Lifting Presser Bar Guide Block Adjusting Screw	214529	omit part	Needle Bar Rock Frame Regulating Stud Spring
200066(804)	omit part	Lifting Presser Bar Guide Block Pinch Screw			
267631	267908	Lifting Presser Bar Lifting Crank with 268258			
32789	267925	Lifting Rock Shaft 267633 with 2022 and 267909			
398865	398868	Lifting Rock Shaft 267925 with 167416, 267621, 267627, 267906, 268491 and three 267617			
32788	267909	Lifting Rock Shaft Crank with 141424(869)			

PARTS TO BE ADDED

PART NUMBER	DESCRIPTION	PART NUMBER	DESCRIPTION
<u>FOR 300W194 AND 300W294</u>			
22988	Anti-reversing Roller Clutch complete, Nos. 22983, 22985, 22986 and 22987	270026	Anti-reversing Roller Clutch Releasing Latch Stud Spring
22982	Anti-reversing Roller Clutch	200078(806)	Anti-reversing Roller Clutch Releasing Latch Stud Socket Screw (2)
22983	Anti-reversing Roller Clutch Bushing with two 200346(830)	22970	Anti-reversing Device complete, Nos. 22988, 22990 and two 200078(806)
200346(830)	Anti-reversing Roller Clutch Bushing Set Screw (2)	268489	Feed Driving Eccentric Stop
22984	Anti-reversing Roller Clutch Housing	<u>FOR 300W294 ONLY</u>	
22985	Anti-reversing Roller Clutch Housing 22984 with 22982	268151	Needle Holder with two 50014(830) for 3/16" to 11/32" gauges. Furnished as regular to the machine in standard gauges of 1/4" (Code 016) and 5/16" (Code 020).
22986	Anti-reversing Roller Clutch Retaining Washer	NOTE:	When ordering, state code or gauge required.
22987	Anti-reversing Roller Clutch Retaining Washer Retainer	or	
22990	Anti-reversing Roller Clutch Releasing Latch complete, Nos. 22989, 29481, 29482, 268416, 268418 and 270026	268152	Needle Holder with two 50014(830) for 3/8" to 5/8" gauges. Furnished as regular to machine in standard gauges of 3/8" (Code 024) and 1/2" (Code 032).
22989	Anti-reversing Roller Clutch Releasing Latch	NOTE:	When ordering, state code or gauge required.
29481	Anti-reversing Roller Clutch Releasing Latch Hinge Pin	or	
268416	Anti-reversing Roller Clutch Releasing Latch Stud	268154	Needle Holder with two 50014(830) for 21/32" to 7/8" gauges. Furnished as regular to machine in standard gauge of 3/4" (Code 048).
29482	Anti-reversing Roller Clutch Releasing Latch Stud Pin	NOTE:	When ordering, state code or gauge required.
268418	Anti-reversing Roller Clutch Releasing Latch Stud Socket	50014(830)	Needle Set Screw (2)

From the library of: Diamond Needle Corp

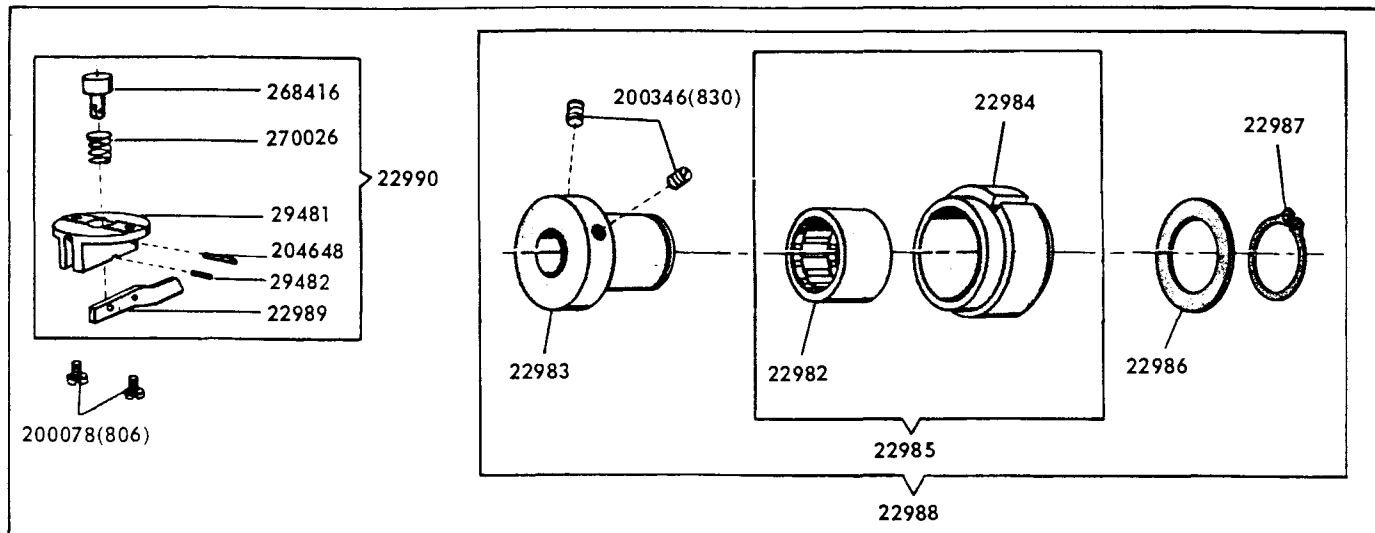



**SUPPLEMENTARY PARTS LIST FOR MACHINE 300W204**  
 (Same as Complete List for MACHINE 300W104 with the following EXCEPTIONS)

CHANGE 300W104 LIST AS INDICATED

PARTS TO BE ADDED

300W104 NUMBER	NEW NUMBER	DESCRIPTION	PART NUMBER	DESCRIPTION
267606	268017	Bed Slide with two 268022 and four 200138(804)	268151(016)	Needle Holder with two 50014(830)
200164(819)	200138(804)	Bed Slide Spring Screw (4)		
267644	267802(816)	Feed Dog, 46 needle hole, with two 267665 and four 200172(804) for 267851		
267632	267676(016)	Lifting Presser Foot with 200078(806)		
267665	268318	Loop Deflector		
200907(819)	200172(805)	Loop Deflector Screw (4)		
268602	268103(016)	Looper Holder with four 350478(833)		
268603	268136	Needle Bar		
398872	398867	Needle Bar Rock Frame 267637 with 267657, 268136, and two each 200173(804), 268144 and 268278		
200125(833)	50014(830)	Needle Set Screw (2)		
167447	167448	Machine Base Oil Drain Jar		
268638	268374(016)	Spreader with two 268162		
228745	228746	Thread Unwinder, complete		
34728	267851(016)	Throat Plate		
267659	267679(016)	Vibrating Presser Foot with 200078(806)		

CHANGE 300W104 LIST AS INDICATED

PARTS TO BE ADDED

300W104 NUMBER	NEW NUMBER	DESCRIPTION	PART NUMBER	DESCRIPTION
268150	omit part	Needle Bar Rock Frame Regulating Stud complete, Nos. 214529, 264709, 268148 and 268149	29482	Anti-reversing Roller Clutch Releasing Latch Stud Pin
267738	267910	Presser Bar Spring Arm	268418	Anti-reversing Roller Clutch Releasing Latch Stud Socket
34728	32827	Throat Plate	200078(806)	Anti-reversing Roller Clutch Releasing Latch Stud Socket Screw (2)
267657	267918	Vibrating Presser Bar	270026	Anti-reversing Roller Clutch Releasing Latch Stud Spring
267658	267919	Vibrating Presser Bar Hinge Stud	22986	Anti-reversing Roller Clutch Retaining Washer
267659	267916	Vibrating Presser Foot with 200078(806)	22987	Anti-reversing Roller Clutch Retaining Washer Retainer
994719	omit part	Air Compressor	22970	Anti-reversing Roller Clutch complete, Nos. 22988, 22990 and two 200078(803)
995475	omit part	Air Filter	143024	Arm Hole Plug for plugging Needle Bar Rock Frame Regulating Stud Hole
160137	omit part	Air Hose	267928	Foot Lifter Crank Stop
167447	167448	Machine Base Oil Drain Jar	200082(804)	Foot Lifter Crank Stop Screw
267722	omit part	Presser Bar Pressure Control Valve complete	267926	Lifting Eccentric 267610 with 267922
<b>PARTS TO BE ADDED</b>				
PART NUMBER	DESCRIPTION		PART NUMBER	DESCRIPTION
22988	Anti-reversing Roller Clutch complete, Nos. 22983, 22985, 22986 and 22987		267914	Lifting Presser Bar Guide with 175(830)
22982	Anti-reversing Roller Clutch		175(830)	Lifting Presser Bar Guide Clamping Screw
22983	Anti-reversing Roller Clutch Bushing with two 200346(830)		204925	Needle Bar Rock Frame Driving Connection Cap Screw Washer (2)
200346(830)	Anti-reversing Roller Clutch Bushing Set Screw (2)		32840	Needle Bar Rock Frame Driving Eccentric complete, Nos. 267610, 268065, 268066, 268067 and 268315
22984	Anti-reversing Roller Clutch Housing		268066	Needle Bar Rock Frame Driving Eccentric Adjusting Disc Spring
22985	Anti-reversing Roller Clutch Housing 22984 with 22982		268067	Needle Bar Rock Frame Driving Eccentric Adjusting Disc Spring Collar with two 200382(833)
22989	Anti-reversing Roller Clutch Releasing Latch		200382(833)	Needle Bar Rock Frame Driving Eccentric Adjusting Disc Spring Collar Set Screw
22990	Anti-reversing Roller Clutch Releasing Latch complete, Nos. 22989, 29481, 29482, 268416, 268418 and 270026			
29481	Anti-reversing Roller Clutch Releasing Latch Hinge Pin			
268416	Anti-reversing Roller Clutch Releasing Latch Stud			